

Owner's manual

ZX-series



Class D, Competition Bass/SPL Amplifier

Before operating the unit, please read this manual thoroughly
and retain it for future reference.

Protect your  Investment

Note your information below for reference:

Model # _____ Serial # _____

Date Purchased _____

And: *Register your Zapco product now*

At: www.zapco.com

Mission Statement

Committed to excellence

Zapco is dedicated to the pursuit of audio fidelity. Our prime objectives are to design and manufacture audio products of unsurpassed quality, to provide unparalleled support and service for these products, and to conduct business in a manner that will enhance the quality of life for all involved.

Experience: Knowledge from doing

There is absolutely no substitute for experience; that is a simple fact of life. Another simple fact is that **Zapco** has, for over forty years, been the leader in defining quality standards for the car audio industry. These years of experience have led to a thorough understanding of the challenges that are unique to the world of car audio. **Zapco's** relentless quest for sonic purity consistently yields imaginative designs that utilize the most innovative technologies. The resulting products set the criteria by which all others in the industry are judged.

The Zapco ZX-Series

The Z-Series of Zapco amplifiers is the result of our experience over the last 40 years with the technology of sound reproduction, combined with what we have learned in consultations with the home and car audiophile communities over the last few years about human perception of sound. We have also used a number of studies of the human physiology to examine what an amplifier should do to make reproduced music sound more like live music.

What did we discover? The proper combination of output devices, op-amps, capacitors and other internal components makes a huge difference in the quality of the sound an amplifier produces. We also determined that with technological advances over the last 10 years we could now develop a more efficient Class D amplifier that would have the SQ specs at 1Ω to equal or even surpass those of most A/B amps.

What we did: We set our standards for specifications in Class A/B and Class D and assured that all amps would meet them. Then we used the best combination of tantalum capacitors, electrolytic capacitors, NJM 5532 and OPA 2134 op-amps, and Sanken and KEC high speed bi-polar output devices, and MOSFET output devices for the Class D amplifiers, to produce what we believe are the best sounding amplifiers we have ever offered.

The **ZX-Series Class D** line-up takes the Z-Series to a whole new place of **Crazy Power** 6,500 watts, 10,000 watts, or 24,000 watts. Now that's *Crazy Power*

Like we say, these are the amps to use "when too much is just not quite enough".

Read, Use, and Enjoy

Yes, please read this manual thoroughly. We wrote it to help ensure that you get the most from your investment in your Zapco amplifier. If you find, after reading the manual, that you still have questions please feel free to give us a call at 1(800)47-FORCE, or, drop us a note at **www.zapco.com**

Power and Wire Gauge

We'll leave the wire chart out of this manual. If you don't have experience working with multiple battery, high amperage systems you should not be installing these amplifiers. *They will eat you alive.*

"Professional" is a word applied to way too many consumer products these days. But these ZX-Series are not consumer products. They are absolutely professional products and they require professional installation. Hire a professional to build the system and design a power distribution system that will support the current draw of the amplifiers.

And remember... Current in the amplifier runs in a complete circuit from the battery to the amp and back to the battery through the chassis and frame. The ground wire is just as important as the power input wire. **Positive and Negative connections must always use the same gauge wire.**

Installation Guidelines

Mounting your Reference Amplifier is easy. Keep in mind the following guidelines:

- The amplifier may be mounted in any direction, on wood, metal or carpet. The metal case of the amplifier may be grounded or left isolated.
- The amplifier requires adequate ventilation. Position the amplifier with sufficient surrounding area for proper cooling. Keep fan and vent endplates clear for proper internal cooling.
- Keep the amplifier out of the engine compartment and other locations that may cause excessive heat or moisture.
- Make sure your ground point is at the frame or a chassis point with direct frame contact. Note: the "quiet metal" on many new cars make body panels very bad ground points, so always try to use the frame.
- Do not mount the amplifier to a subwoofer enclosure or any other place that may have excessive vibration!

Gain Setting

Matching Your Components for Best Sound

Proper gain setting is one of the most important factors in setting up a stereo system. At the same time, gain setting is most often done wrong. Turning up the gain of an amp is the very last thing you should ever do to a system.

An amplifier is a step up transformer. Period. Any signal you put in is boosted by a fixed factor. Music, hiss, or any other noise, it doesn't matter. A large number of noise problems are simply a matter of improper gain settings. The goal of gain setting is to achieve the maximum amount of musical output from the amplifier while getting the least amount of hiss or noise from the system. Your Z-Series Series amplifier accepts an extremely wide range of input levels. As little as .5 volts on the RCAs to as much as 8 volts. The basic gain setting is very simple and requires no special tools. Whether you have a simple system with a deck and an amp, or a system with a deck, line driver, equalizer, crossover, and amp, the procedure is always the same. First, hook up the system with all gain controls at minimum (turn the gain pot fully counter-clockwise with a small screwdriver). Then turn on the head unit and turn up the volume. If you achieve clean sound, and, more volume than you want, you don't need to make any adjustments. However, if you turn up the volume and begin to hear distorted sound before it becomes loud, you are clipping (distorting) the deck (probably a little over $\frac{3}{4}$ volume). Turn the deck down just enough to hear clean sound again, and then move to the next component in your system. With the deck playing at "maximum clean volume" adjust the gain of the next component to its "maximum clean volume". If you adjust your gains this way, always starting at the head unit and working down the line to the amplifier, you will get the most performance out of your amplifier(s) with the least amount of unwanted distortion and noise.

Presenting
The Zapco ZX-Series
Competition, Class D, SPL Amplifiers

FEATURES

■ ZX-6.5KD / ZX-10KD

- SPL competition class-D linkable mono block amplifier
- Dual MOS-FET PWM power supplies
- Daisy-chain Pass-through output
- Double sided through hole epoxy PCB
- Stable into 1 ohm
- 24dB/oct variable crossover
- Variable 24 dB low pass (LPF) crossover
- Variable 12 dB bass boost equalization control
- Variable 180 degree adjustable phase shift
- Variable 24 dB subsonic filter
- Efficiency : 86% @ 4 ohm, at 100Hz
- Selectable for MASTER and SLAVE operation to strap amplifiers
- Multi-way protection circuitry
(thermal/over current/speaker short/speaker DC protection)
- RCA line input and line out
- Heavy duty copper layer double sided epoxy PCB
- 2 x 0 Gauge (AWG) battery input connectors (ZX-6.5KD)
- 3 x 0 Gauge (AWG) battery input connectors (ZX-10KD)
- Efficiency: 86% at 4 ohm, 100 Hz
- Tested voltage & THD : 14.4V & < 0.5% THD
- Operating voltage: DC 10V ~ 16V
- Wired remote control

■ ZX-26KD

- SPL competition class-D mono block amplifier
- Four huge MOS-FET PWM power supplies
- Double sided through hole epoxy PCB
- 24dB/oct variable crossover
- Variable 24 dB low pass (LPF) crossover
- Variable 12 dB bass boost equalization control
- Variable 180 degree adjustable phase shift
- Variable 24 dB subsonic filter
- Efficiency : 86% @ 4 ohm, at 100Hz
- Multi-way protection circuitry
(thermal/over current/speaker short/speaker DC protection)
- RCA line input and line out
- Heavy duty copper layer double sided epoxy PCB
- 6 x 0 Gauge (AWG) battery input connectors
- Efficiency: 86% at 4 ohm, 100 Hz
- Tested voltage & THD : 14.4V & < 0.5% THD
- Operating voltage: DC 10V ~ 16V
- Wired remote control

POWER CONNECTION

■ ZX-6.5KD

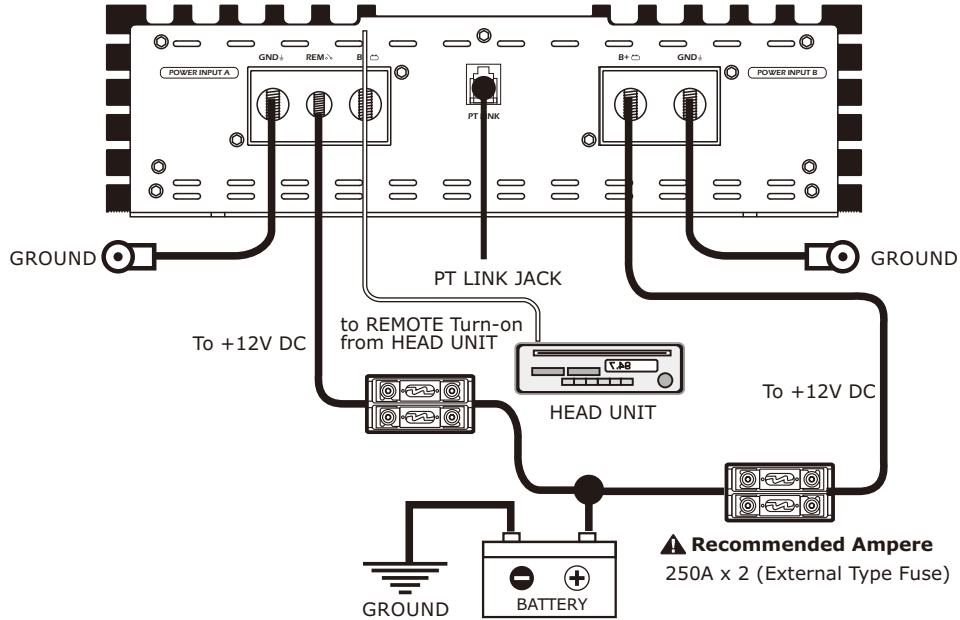

■ ZX-10KD

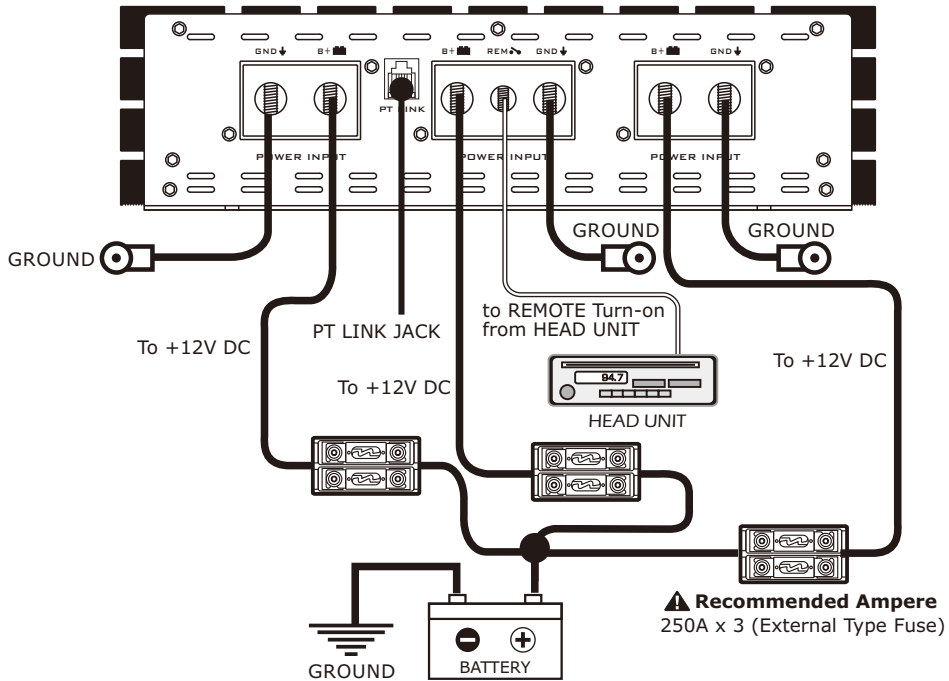

POWER CONNECTION

■ ZX-26KD

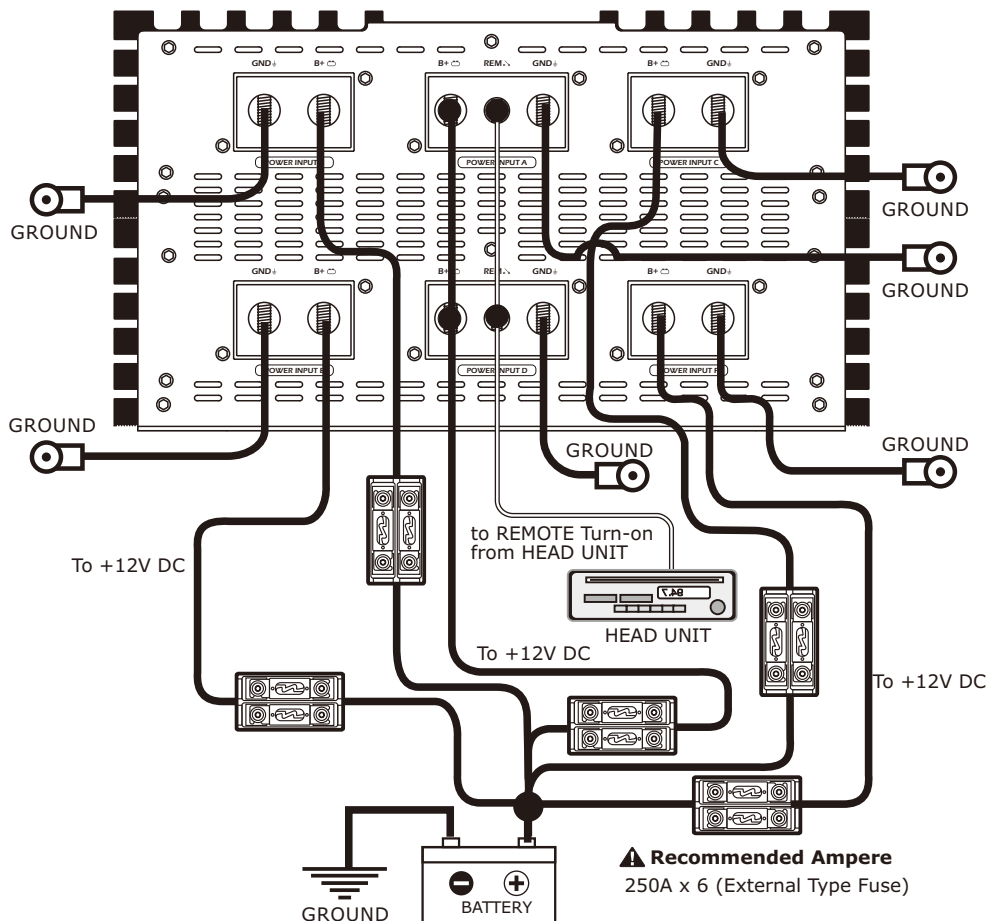

+12V Power

Connect the +12V terminal of the amplifier to the + terminal of the battery using the same diameters the power and ground cables, making sure you install in-line fuse holders, approximately 12" from the + terminal of battery, making sure that there is no fuse in the battery holder.

GROUND

Disconnect the battery and connect the GND (ground) terminal to the cars chassis. Keep this cable as short as possible (not longer than 500 mm. or less). This connection **MUST** be made at the frame and be rust free and clear of paint or grime.

REMOTE

Connect the REM terminal of the amplifier to the =12 Trigger out of the source unit, or an accessory terminal at the fuse box or ignition switch.

⚠ Caution

First make the ground connection, then +12V wire connection, and finally the remote connection. Furthermore, the +12V wire must always be fused at the battery for protection against possible damage. If you need to replace the power fuse, replace it with a fuse of the same value. It may result in a serious hazard to use a fuse of a different type or rating.

RCA CONNECTION

■ ZX-6.5KD / 10KD

Single Amplifier Application

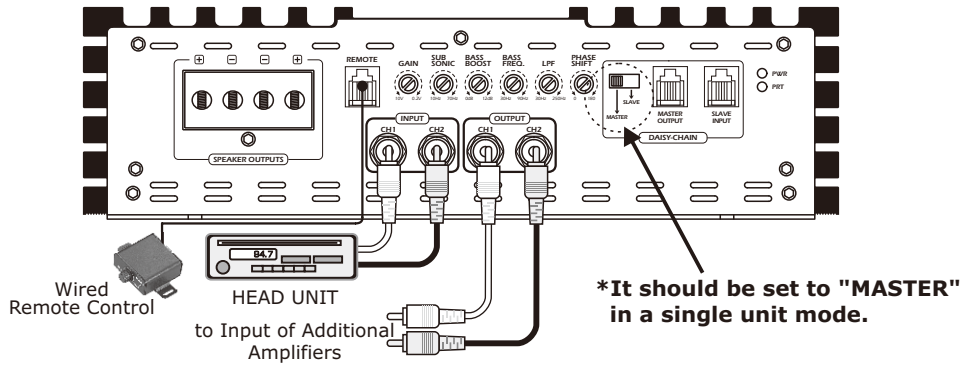

2 Amplifiers in Parallel Application (MASTER & SLAVE RCA Connection)

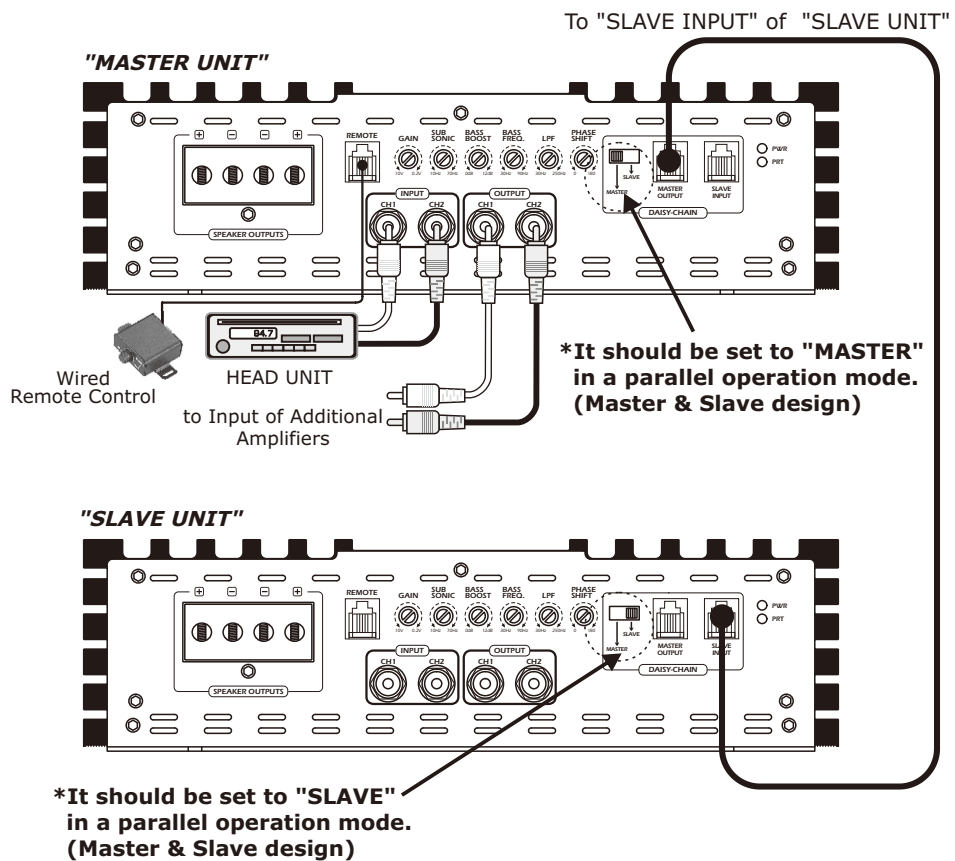

RCA CONNECTION

■ ZX-26KD

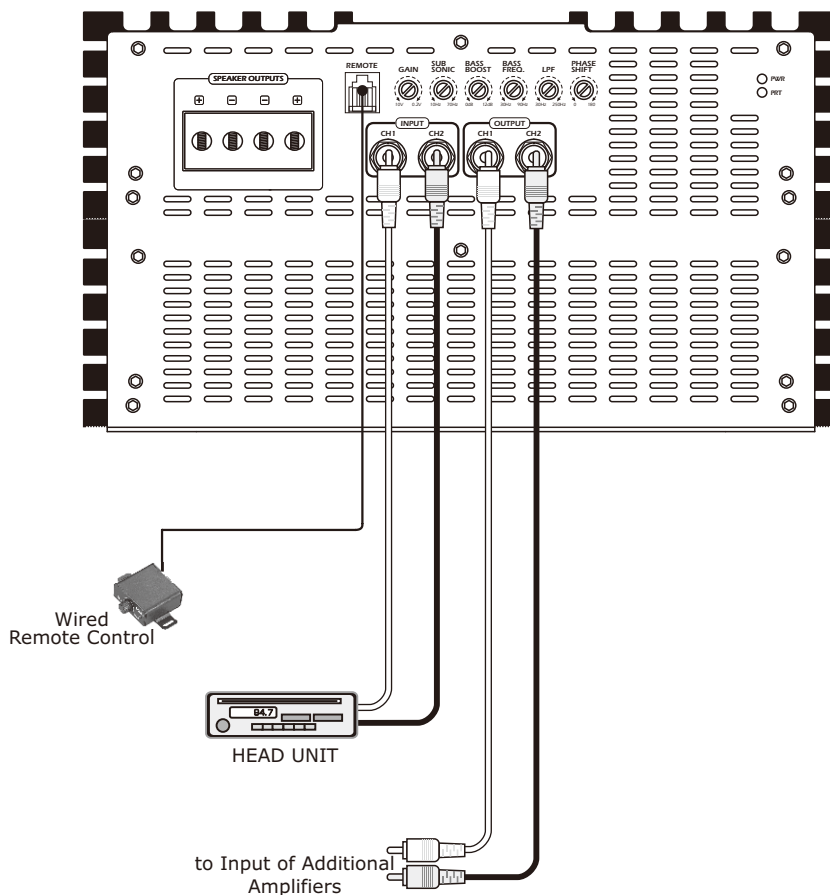

RCA connectors are used for the input from the systems source unit.
A second set of RCAs provides an output to feed the inputs of another amplifier.
The amplifier gain control lets you match the amplifier input levels to the source units output level

Warnings!

Potentially lethal voltages inside! The 6.5KD, 10KD and 26KD have voltage rails exceeding **300 Volts AC**
Do not open the case - no adjustments inside

Also:

The Outputs of these amps carry more voltage than the wall plugs in your house. *Don't touch the outputs while the amplifiers are working*

SPEAKER CONNECTION

■ ZX-6.5KD / 10KD

Single Amplifier Speaker Connection

1~4 ohms

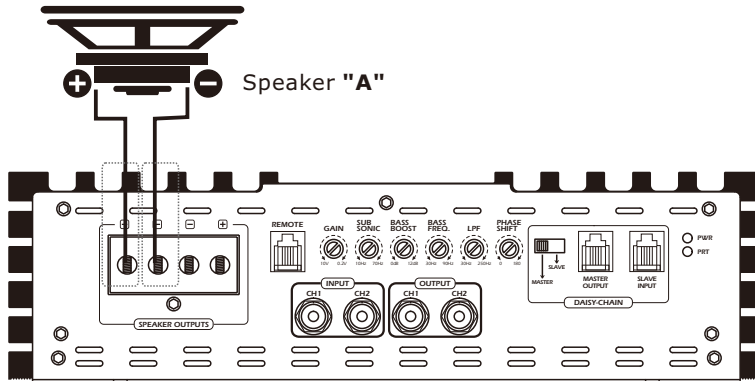

2~8 ohms

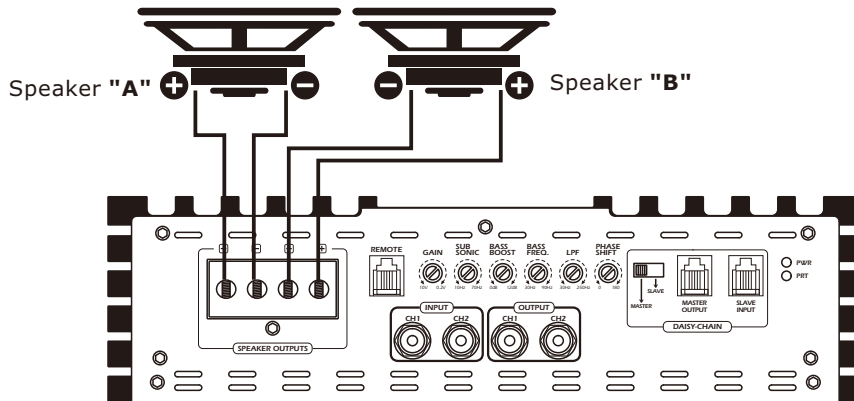

Please note that this unit is a mono block unit and has only one channel. Speaker A and Speaker B are just labeled for clear illustration. For example, if you connect two 2 ohm subwoofers, the amp will parallel the connections for an 1 ohm load.

SPEAKER CONNECTION

■ ZX-6.5KD / 10KD

Dual Amplifier Speaker Connection

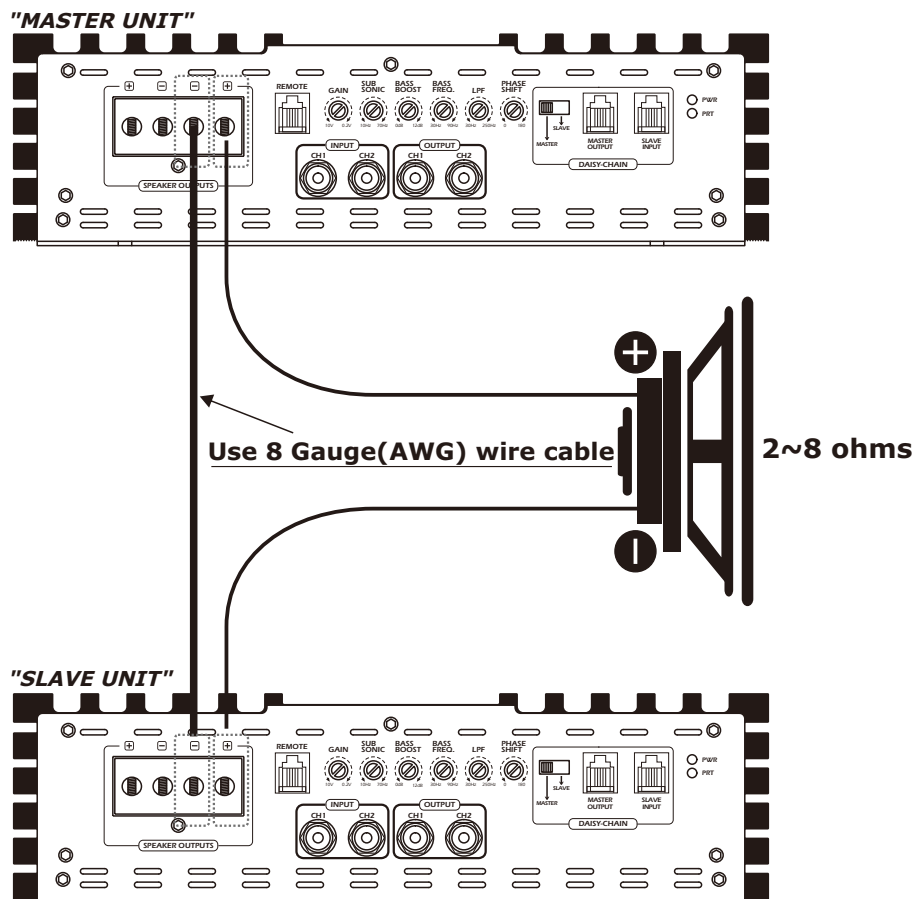

Using a dual amplifier configuration, the MASTER amplifier has total control over the SLAVE amplifier. The positive terminal of the subwoofer's voice coil must be connected to the positive terminal of the MASTER Amplifier and the negative terminal of the subwoofer's voice coil must be connected to positive terminal of the SLAVE Amplifier. Since the dual amplifier configuration has tremendous output potential, please ensure that your subwoofers can handle such a large amount of power.

⚠ Caution

When utilizing the dual amplifier configuration, it is important to note that the connected speakers' load cannot be lower than 2 ohms. Connecting a lower impedance load can damage the amplifier and void your warranty.

SPEAKER CONNECTION

■ ZX-26KD

Single Voice

4 Ohm Load

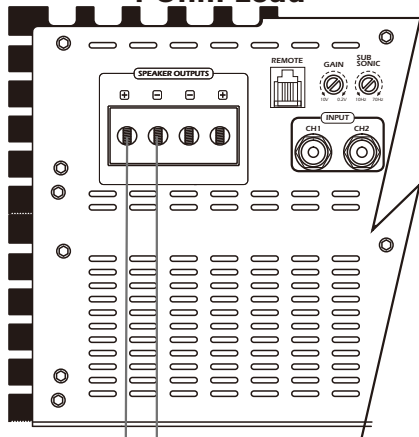

SUBWOOFER
(4 Ω Single Voice Coil)

2 Ohm Load

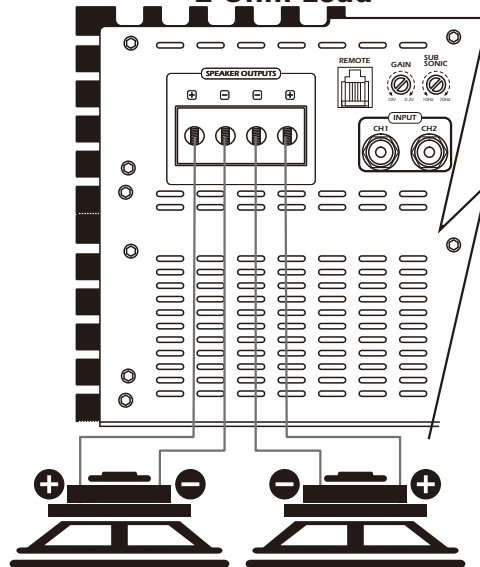

SUBWOOFER x 2
(4 Ω Single Voice Coil)

1 Ohm Load

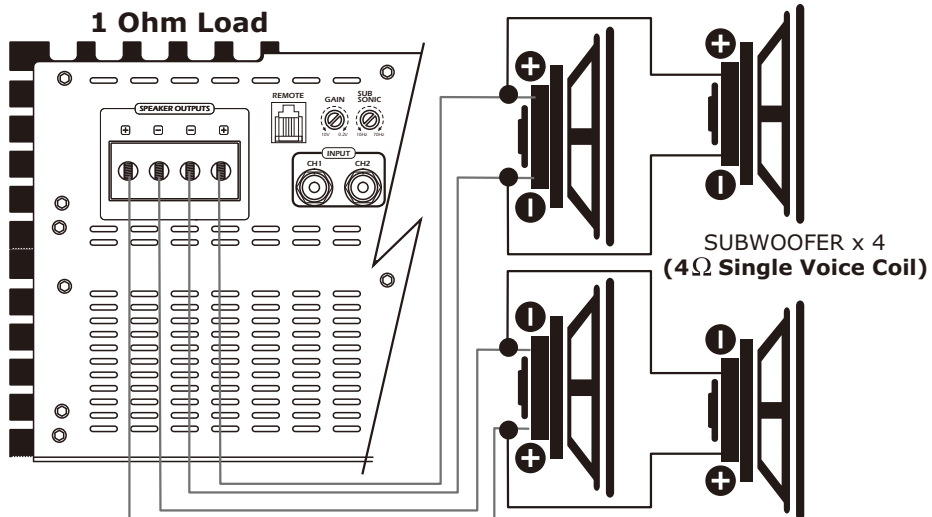

SUBWOOFER x 4
(4 Ω Single Voice Coil)

⚠ Caution

This amplifier is not supplied with Bridged Mode. If you use this amplifier in Bridged Mode, catastrophic damage will likely occur.
Use the amplifier in MONO mode only, in compliance with above drawings.

SPEAKER CONNECTION

■ ZX-26KD

Dual Voice

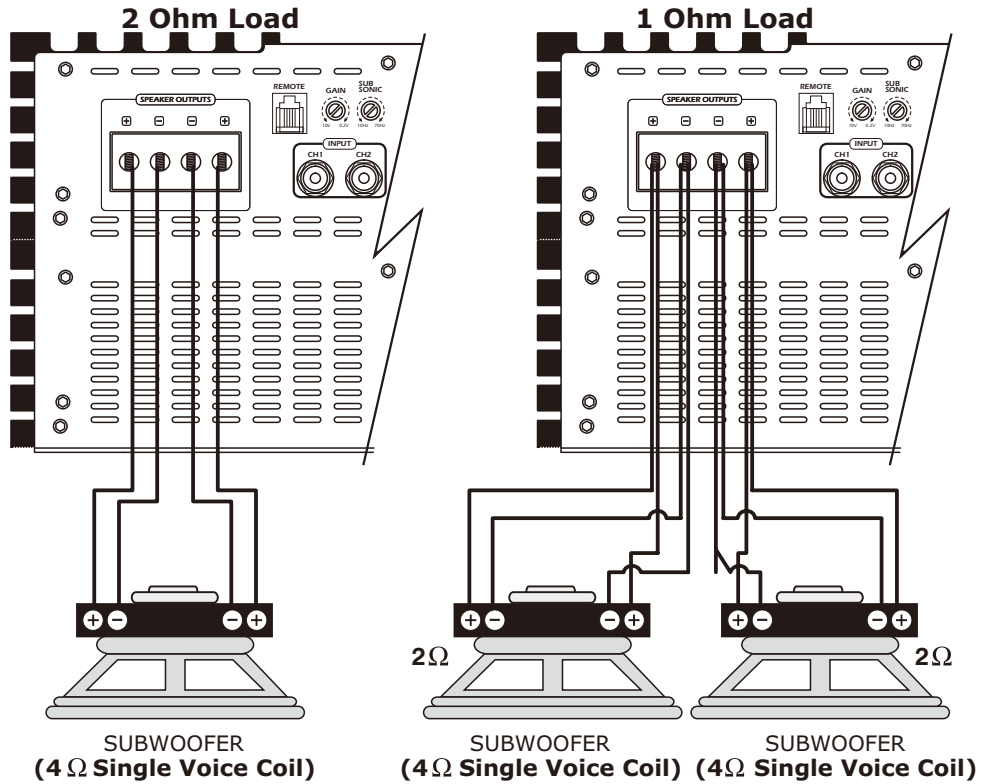

⚠ Caution

This amplifier is not supplied with Bridged Mode. If you use this amplifier in Bridged Mode, catastrophic damages may occur. Use the amplifier in MONO mode only in compliance with above drawings.

SPECIFICATIONS

	■ ZX-6.5KD	■ ZX-10KD
Rated power output		
-RMS power, 1 ohm (12.0V) -----	4530W x 1CH	7050W x 1CH
-RMS power, 1 ohm (14.4V) -----	6510W x 1CH	9780W x 1CH
-RMS power, 1 ohm (16.0V) -----	6750W x 1CH	10940W x 1CH
2 Same units linked in parallel		
-RMS power, 2 ohm (12.0V) -----	9060W x 1CH	14500W x 1CH
-RMS power, 2 ohm (14.4V) -----	13020W x 1CH	20000W x 1CH
-RMS power, 2 ohm (16.0V) -----	13500W x 1CH	22000W x 1CH
Signal to noise ratio -----	>90dB	>90dB
Low pass frequency crossover -----	30Hz~250Hz	30Hz~250Hz
Subsonic filter -----	10Hz~70Hz	10Hz~70Hz
Bass boost @ 45Hz -----	0~12dB	0~12dB
Bass boost Frequency-----	30Hz~90Hz	30Hz~90Hz
Phase shift control -----	0~180 degree	0~180 degree
Frequency response -----	10Hz~350Hz (+/- 1dB)	10Hz~350Hz (+/- 1dB)
THD@RMS watts -----	<1.0%	<1.0%
Efficiency @ 4 ohm -----	86%	86%
Fuse rating -----	250A x 2(external type fuse)	250A x 3(external type fuse)
Input sensitivity -----	200mV ~ 10V (+/- 5%)	200mV ~ 10V (+/- 5%)
Dimensions (mm) -----	280(W) x 77(H) x 600(L)	280(W) x 77(H) x 940(L)

	■ ZX-26KD
Rated power output	
-RMS power, 2 ohm (12.0V) -----	14500W x 1CH
-RMS power, 2 ohm (14.4V)-----	20000W x 1CH
-RMS power, 2 ohm (16.0V)-----	22000W x 1CH
Signal to noise ratio -----	>90dB
Low pass frequency crossover -----	30Hz~250Hz
Subsonic filter -----	10Hz~70Hz
Bass boost @ 45Hz -----	0~12dB
Bass boost Frequency-----	30Hz~90Hz
Phase shift control -----	0~180 degree
Frequency response -----	10Hz~350Hz (+/- 1dB)
THD@RMS watts -----	<1.0%
Efficiency @ 4 ohm -----	86%
Fuse rating -----	250A x 6(external type fuse)
Input sensitivity -----	200mV ~ 10V (+/- 5%)
Dimensions (mm) -----	280(W) x 154(H) x 940(L)

The above specifications shall be modified by manufacturer for improvement without prior notice.

TROUBLE SHOOTING GUIDE

This power amplifier has protection features to prevent most forms of damage. If the unit senses excessive heat, short circuited speakers or overload, the protection indicators will be lit and the system will be turned off. Prior to checking the wiring for any fault, you should turn all level controls down and turn off power. If the amplifier shuts down due to excessive heat, the protection indicators will not be lit; simply allow the amplifier to cool down. Before removing your amplifier, refer to the list below and follow the suggested procedures. Always test the speakers and their wires first.

AMPLIFIER IS NOT POWERED UP

- ◆ Check if at least +12V DC is present on the battery power terminal.
- ◆ Check if at least +13.8V DC is present on the remote terminal.
- ◆ Check if a good ground connection is present. Check all fuses.
- ◆ Check if the protection LED is not lit.

PROTECTION LED ILLUMINATES WHEN AMPLIFIER IS POWERED UP

- ◆ Check to see if any speaker wires are short-circuited to the chassis or themselves.
- ◆ Remove speaker wires and reset the amplifier. If the protection LED still comes on, then the amplifier is at fault.

FUSE BLOWING

- ◆ Check if the minimum speaker impedance is met.
- ◆ Check for short-circuits on power cable and vehicle chassis.

OVERHEATING

- ◆ Check if the minimum speaker impedance is met.
- ◆ Check speakers for short-circuits.
- ◆ Check if there is good airflow around the amplifier

SOUND TOO LOW-DISTORTED SOUND

- ◆ Check if the input level control is set to match the output level of the source unit.
- ◆ Check the head unit's volume.
- ◆ Check speakers for short-circuits
- ◆ Check if crossover frequencies have been properly set.

HIGH HISSING NOISE - ENGINE NOISE IN SPEAKERS

- ◆ Check if a good ground connection is present. Most engine noises are caused by grounding issues.
- ◆ Hissing noise is most often caused by gain issues. Proper gain matching is usually required to eliminate hissing noise.



The Zapco Z-Series is a joint venture of ARPA of America and ARPA Italy and is manufactured in Korea

ARPA of America Corporation
3037 E Palm Ave Suite 101
Manteca, CA 95337
Phone: (800) 47-Force